

LINEAR STRUCTURAL ELEMENTS
CROSS-BAR AND BEAM

AS Tartu Maja Betoontooted manufactures bar elements with the product name cross-bar and beam in conformity with the standard EVS-EN 13225 "Precast concrete products. Linear structural elements" and EVS-EN 13369 "Common rules for precast concrete products". Cross-bars and beams are usually horizontal bar elements, based on bending. Cross-bars and beams are manufactured of reinforced concrete and stressed concrete.

M A T E R I A L S

The following materials are used at the production of cross-bars and beams:

- normal-weight concrete with the strength class of at least C40/50, with production and characteristics conforming to the standard EVS-EN 206-1 "Concrete. Specification, performance, production and conformity";
- 7-wire strand as pre-stressed reinforcement, with characteristics conforming to standard prEN 10138-3 "Pre-stressing steels. Part 3: Strand".
- reinforced steel as non-pre-stressed reinforcement with qualities conforming to the standard EVS-EN 10080 "Steel for the reinforcement of concrete. Weldable reinforcing steel".



P R O D U C T I O N

Cross-bars and beams are manufactured on heated pre-stressing casting beds with the length of 13-62 m (on the so-called force floor) by moulding with framework. Pre-stressed crossbars and beams use pre-stressed and non-pre-stressed longitudinal reinforcements in the compressive and tensile zone. Products with similar reinforcements on the casting bed are separated from each other by formwork. The outermost two strand pairs are installed into plastic pipes with the length of 0.5-1.0 m in case of a big number of strands for damping the impact generated at the pre-stressing of products. Stirrups with uniform distances are installed for receiving the shearing force, at cross-bar ends (biggest shear force) additional stirrups are installed.

The pre-stressing strength of concrete $f_{cm,p}$ is at least 25 MPa and not less than 1.5 times of the maximum compressive stress of concrete caused by pre-stressing force.

The initial pre-stress of reinforcement strands both in compressive and tensile zone does not exceed 1300 MPa.

Neoprene strip is fixed to the shoulders of cross-bars from the edge of the phase, which prevents concrete from pouring out at the assembly of ceiling slabs and evenly divides the load caused by ceiling slabs.

The bottom surface of cross-bars and beams is formed against a steel bed, it is smooth and does not need any additional surface treatment prior to finish. The side surfaces of cross-bars are formed against a veneer formwork, they are also smooth and do not require surface treatment afterwards.

Q U A L I T Y

The quality of the cross-bars and beams is secured by designing methods and factory production control. The production control of the factory includes regular control of all the used devices, materials, elements and the production process itself.

F I R E R E S I S T A N C E

The required fire resistance of the cross-bars and beams is secured by the selection of appropriate cross-section dimensions and the protective layer of reinforcing steel. The fire resistance class of the product is in the range R60 - R120.



PRODUCTION TOLERANCES

The production tolerances of the cross-bars and beams conform to the standard EVS-EN 13225 "Precast concrete products. Linear structural elements" and EVS-EN 13369 "Common rules for precast concrete products", unless working drawings state otherwise.

Table 1.

Production tolerances

Measurement	Tolerance (mm)
Length L	+/- (10 + L/1000) +/- 15
Nominal dimension of cross-section ¹⁾ h = 150 h = 400	+ 10; - 5 +/- 15
Positioning and nominal dimension of openings and cavities, positioning of fastening plates ¹⁾ h = 150 h = 400 h = 2500	+ 15; - 8 +/- 23 +/- 45
Angle deviation of end face or cross-section,	+/- h/100 5
Lateral bow,	+/- L/700
Camber, ²⁾	+/- L/700
Mid plane inclination in the vertical direction	+/- L/700

¹⁾ The intermediate values of nominal dimensions h are interpolated linearly

²⁾ The bending tolerance ? of pre-stressed elements can be multiplied by 1.5

The positioning tolerances of beam shoes conform to producer's requirements.

Symbols in the table of production tolerances are explained in Figure 1.

Figure 1.

Symbols in the table of tolerances

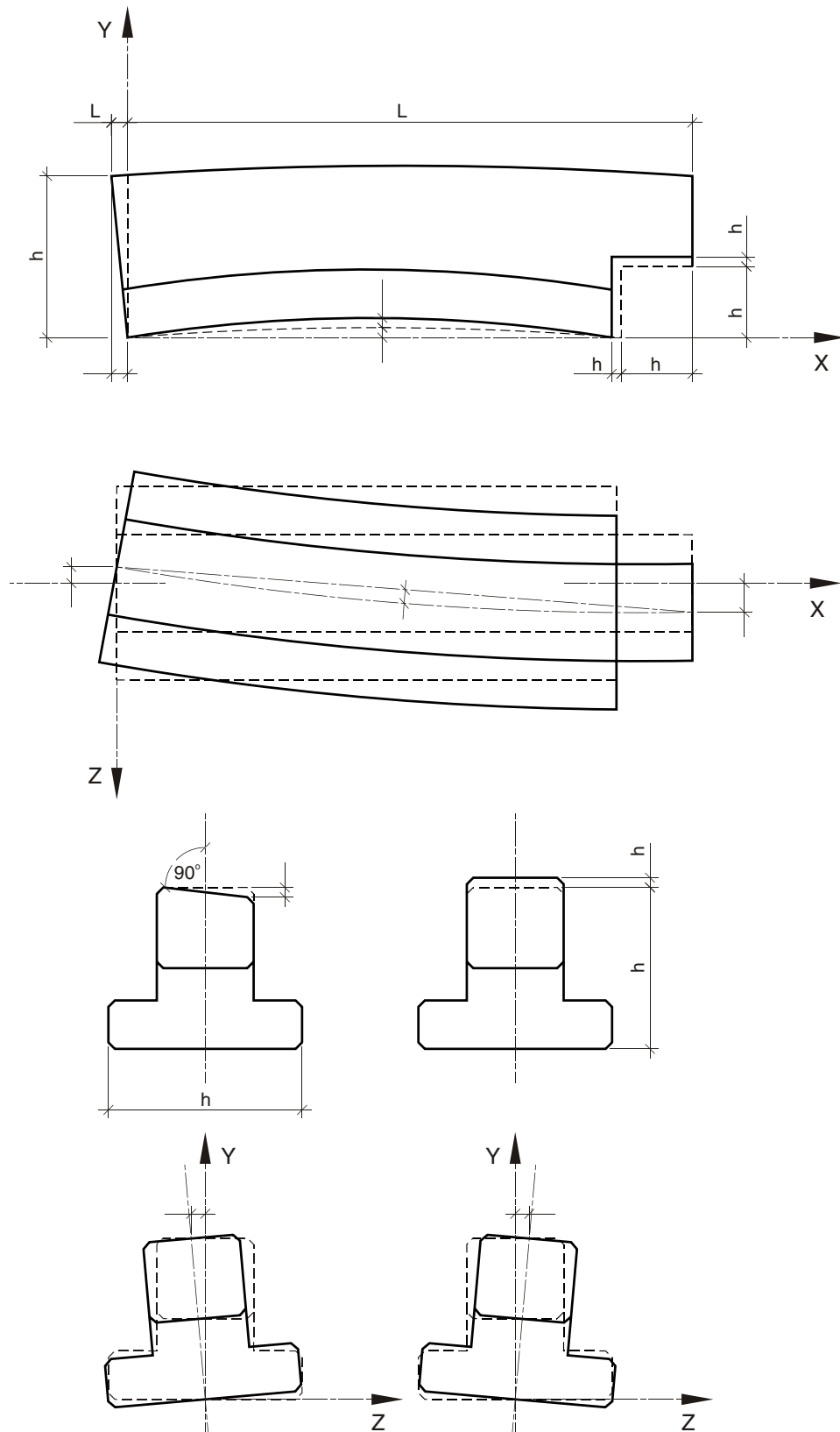



TARTU MAJA
B E T O O N T O O T E D

LINEAR STRUCTURAL ELEMENTS
CROSS-BAR AND BEAM

Bearing capacity
graphs

B E A R I N G C A P A C I T Y G R A P H S

The bearing capacity graphs of pre-stressed cross-bars are presented in Figure 2. The bearing capacity graphs have been compiled for static load and they are suitable only for primary selection of cross-section, the more exact calculations and reinforcement shall be performed by a designer.



Figure 2.

Graphs of the bearing capacity of pre-stressed cross-bars

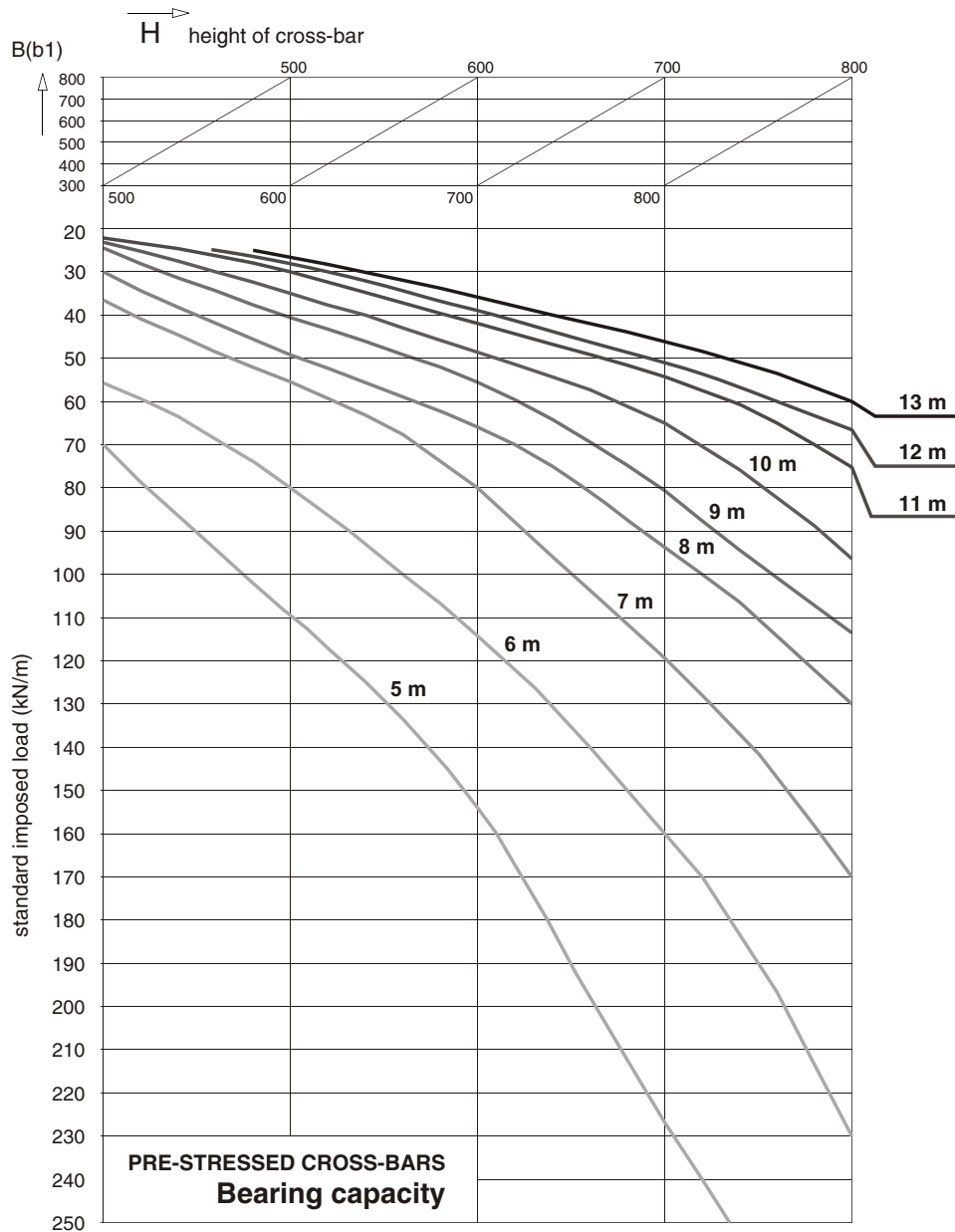

Notes:

- The bearing capacity graphs have been compiled for static load.
- Permanent load forms 50 % of the imposed load
- Concrete class C40/50
- The graphs can be used only for primary selection of cross-section



STANDARD CROSS-SECTIONS

When hollow-core slabs are supported by a pre-stressed cross-bar, the length of the shoulder $b_2 = 150$ mm (see Figures 3...6). The width of the cross-bar = the width of the framework column.

When TT slabs are supported by a pre-stressed cross-bar, the height of the cross-bar depends on the height of TT slabs. The height h_1 changes (400, 500, 600, 700 or 800 mm). The height of the shoulder $h_2 = 300$ mm and the width of the shoulder $b_2 = 200$ mm (see Figures 8 and 9).

Figure 3.

Standard cross-section of a two-sided pre-stressed cross-bar

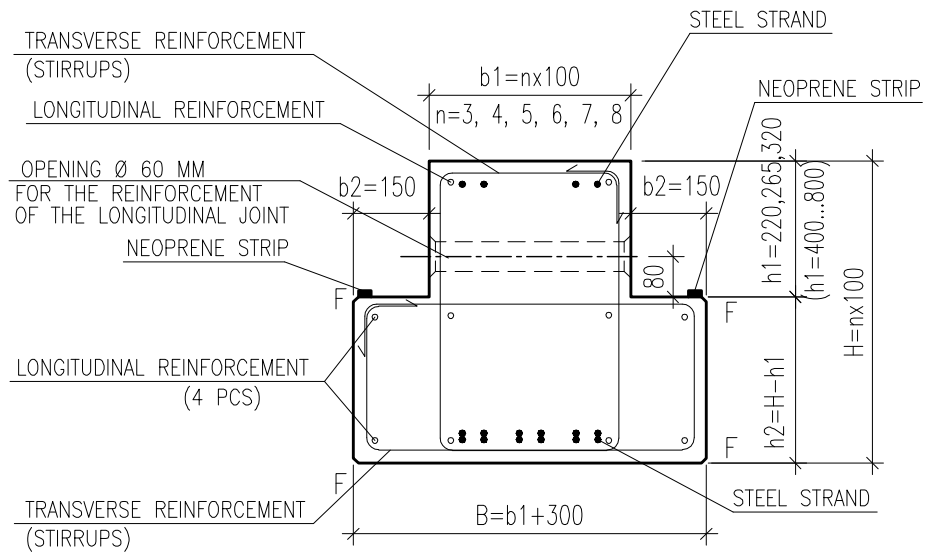

NOTES :
F- PHASE 10x10 MM

Figure 4.

Standard cross-section of a single-sided pre-stressed cross-bar

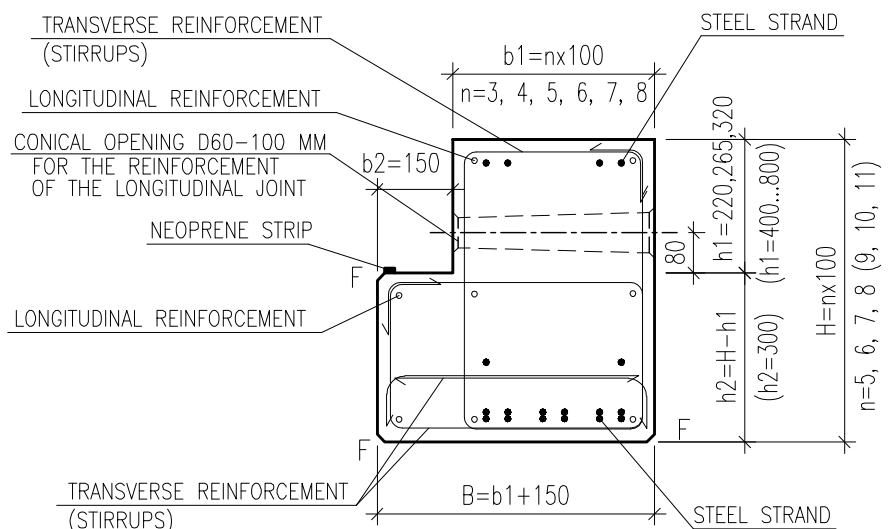

NOTES :
F- PHASE 10x10 MM



Figure 5.

Standard cross-section of a two-sided pre-stressed cross-bar of special shape

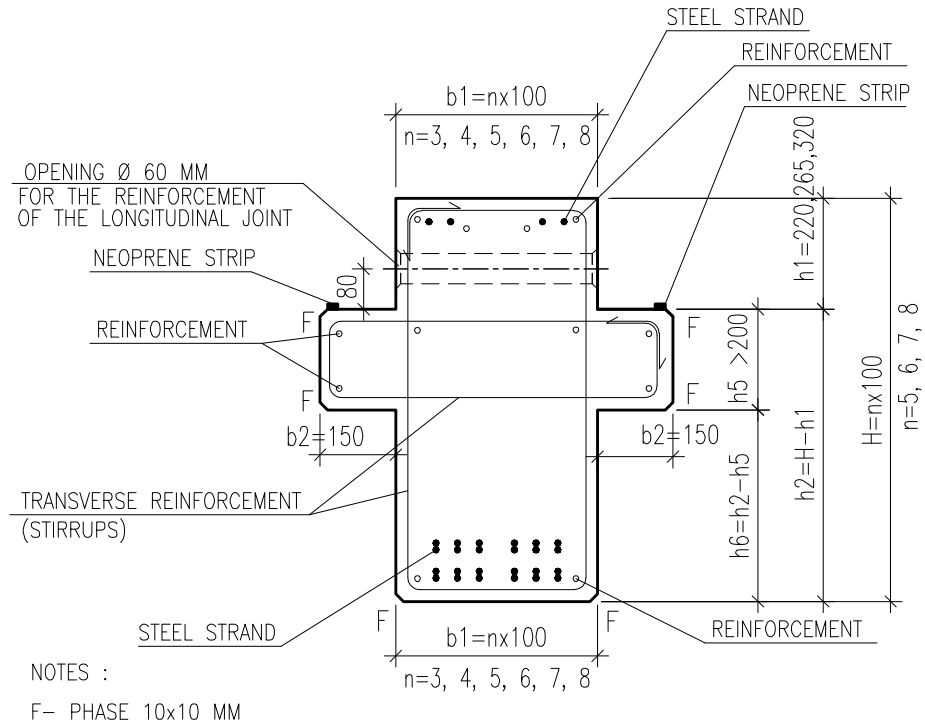
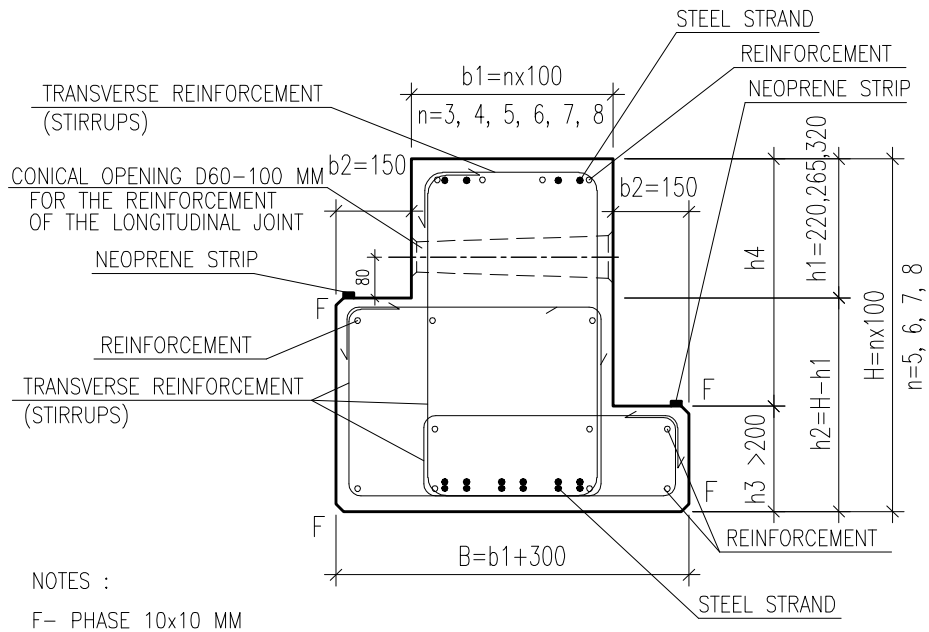

Figure 6.

Standard cross-section of a two-sided pre-stressed cross-bar of with shoulders at different heights





U S A G E

Cross-bars and beams are used mainly at the construction of structural frameworks of industrial and non-residential buildings for supporting ceiling slabs.

The optional length and large bearing capacity of pre-stressed cross-bars enable flexible design and offer many-sided plan and room solutions with long spans. In buildings designed of precast elements, the cross-bars are supported according to simple beam or cantilever beam calculation schemes.

S T O R A G E A N D T R A N S P O R T A T I O N

Pre-stressed cross-bars and beams are always transported in one layer. Cross-bars and beams are stored on a compact horizontal ground. A supporting squared timber of at least 100 x 100 mm is placed directly under both ends of the cross-bar. In case of non-pre-stressed beams the supporting squared timbers and intermediate battens are installed directly next to hoisting eyes.

Cross-bars and beams can be hoisted and transported only from the hoisting eyes designed for that. Traverse is used at hoisting (cross-bars and beams short below 5 m long can also be hoisted only by slings).



A S S E M B L Y

Cross-bars are fastened to frame columns by beam shoes (e.g. Anstar) or supported on concrete cantilevers or brickwork.

Figures 7 and 8 present example joint solutions to supporting hollow-core slabs and Figure 9 presents supporting TT slabs on cross-bars.

Figure 7.

Supporting of hollow-core slabs on two-sided pre-stressed cross-bar

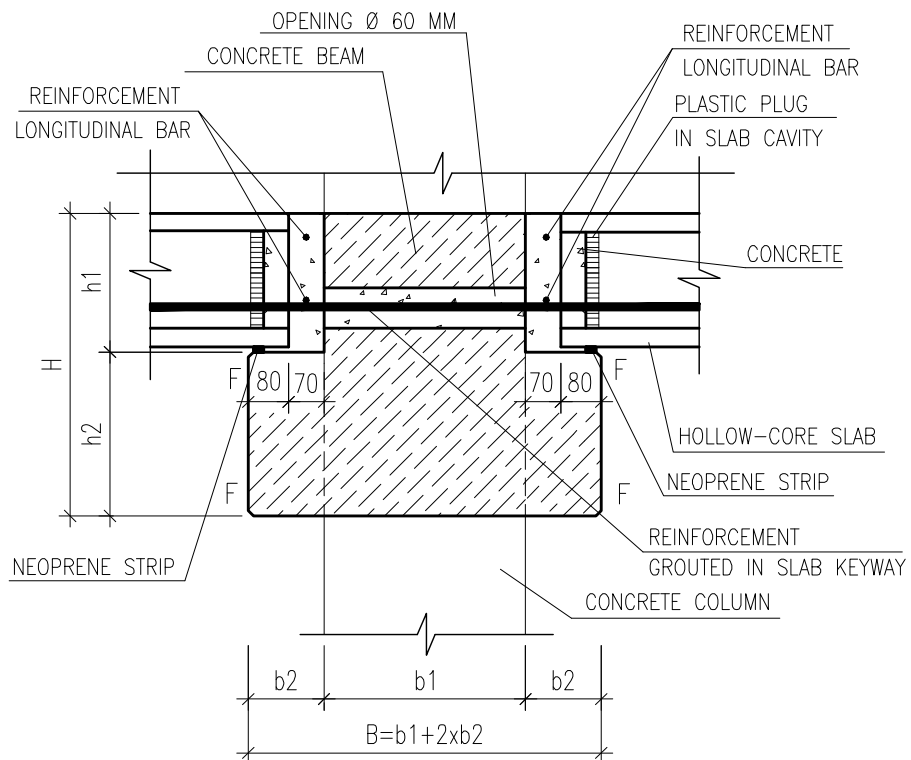

NOTES :

F- PHASE 10x10 MM

Figure 8.

Supporting of hollow-core slabs on single-sided pre-stressed cross-bar

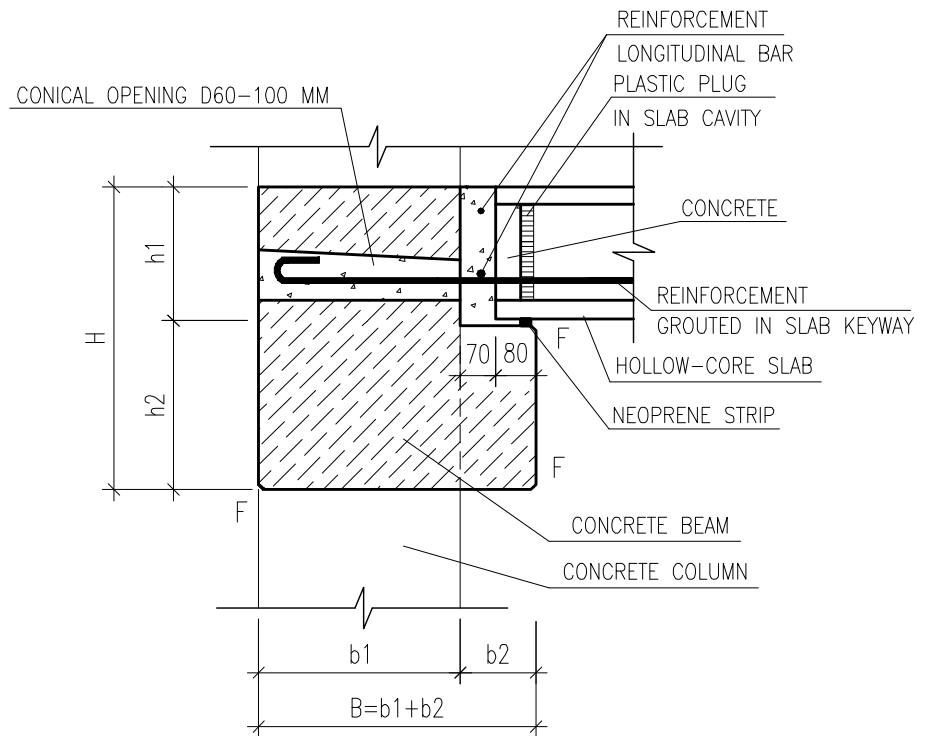

NOTES :

F- PHASE 10x10 MM

Figure 9.

Supporting of TT slabs on single-sided pre-stressed cross-bar

